



The Quality Profile



SOFTLINE AD70

Type	Casement
System Depth	70 mm
U-Value	$U_f=1.3 \text{ W/m}^2\cdot\text{K}$

SOFTLINE AD70

VEKA SOFTLINE AD70 casement system is VEKA's classic 2-Level gasket system with a system depth of 70mm produced around the world at all VEKA subsidiaries to identical specifications.

Optimized and easy automated window fabrication and a wide range of special profiles and add-on profiles make the AD70 the perfect choice for villas and other projects with the need for high variety of different window and door styles and designs. It supports very large window sizes including combination windows. Other than the 3-Level center seal gasket system, 2-Level gasket systems include outward opening windows and doors making the AD70 the most versatile VEKA system. With a 2-Level gasket solution, the height of frame and sash profiles are reduced to allow for very large glazing area ratio, especially important for smaller sized windows. The SOFTLINE AD70 is currently the most widely used 2-Level gasket window and door system by VEKA targeting U_w of 1.3–2.0 $\text{W/m}^2\cdot\text{K}$.

- ◆ System U_f 1.3 $\text{W/m}^2\cdot\text{K}$ (including steel reinforcements)
- ◆ System depth 70mm – 5 Chambers
- ◆ Glazing width range from 21mm – 35mm
- ◆ Glazing depth 21mm
- ◆ Available in profile wall thickness “Class A”
- ◆ Low-energy-house ready

U-Values by Glass configuration

U-Value Std window	Glass Thickness	Glass Configuration	Glass U-Value
1.3 $\text{W/m}^2\cdot\text{K}$	33 mm	5ssLow-E+9Ar+5ssLow-E+9Ar+5	0.95 $\text{W/m}^2\cdot\text{K}$
1.5 $\text{W/m}^2\cdot\text{K}$	33 mm	5ssLow-E+9A+5ssLow-E+9A+5	1.23 $\text{W/m}^2\cdot\text{K}$
1.8 $\text{W/m}^2\cdot\text{K}$	22/24 mm	5dsLow-E+12/14A+5	1.66 $\text{W/m}^2\cdot\text{K}$
2.0 $\text{W/m}^2\cdot\text{K}$	33 mm	5+9A+5+9A+5	1.87 $\text{W/m}^2\cdot\text{K}$

Color options

Standard White		White			
Acryl-Color COEX					
	dark brown	dark grey			
Laminated					
	dark oak	golden oak	mahogany	dark grey	
	Full color profile				
		brown	caramel	dark grey	

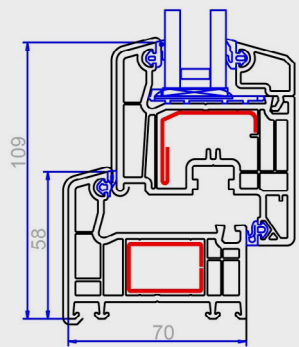

↑ Window Acryl-Color COEX

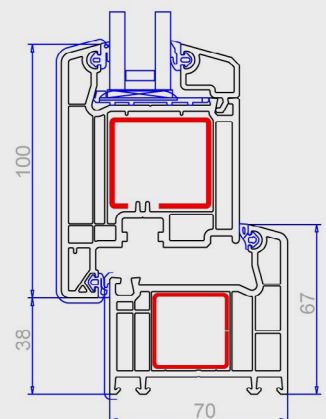

↑ Door Acryl-Color COEX

VEKA Plastics (Singapore) Pte. Ltd.
 10 Anson Road, #15-08
 International Plaza
 Singapore 079903
 T: +65 6324 1533
 E: infoasia@veka.com
 W: www.veka-system.com



Inner Mongolia - Chun Cheng Square

Inner Mongolia is a region with demanding climate: windy, cold and dusty and very high sunlight exposure. To withstand high UV radiation, German imported window lamination foil are the preferred solution. This project is a model case of a low energy building in a harsh climate region, and VEKA's solution was highly appreciated by the developer.

Product	SOFTLINE AD70
U_f	1.3 W/m ² ·K
Glass Configuration	5sslow-E+9Ar+5ssLow-E+9Ar+5
U_w	1.3 W/m ² ·K

